

LU17 Ventilation Deep Fryer - Spray Tunnel

Control room GF

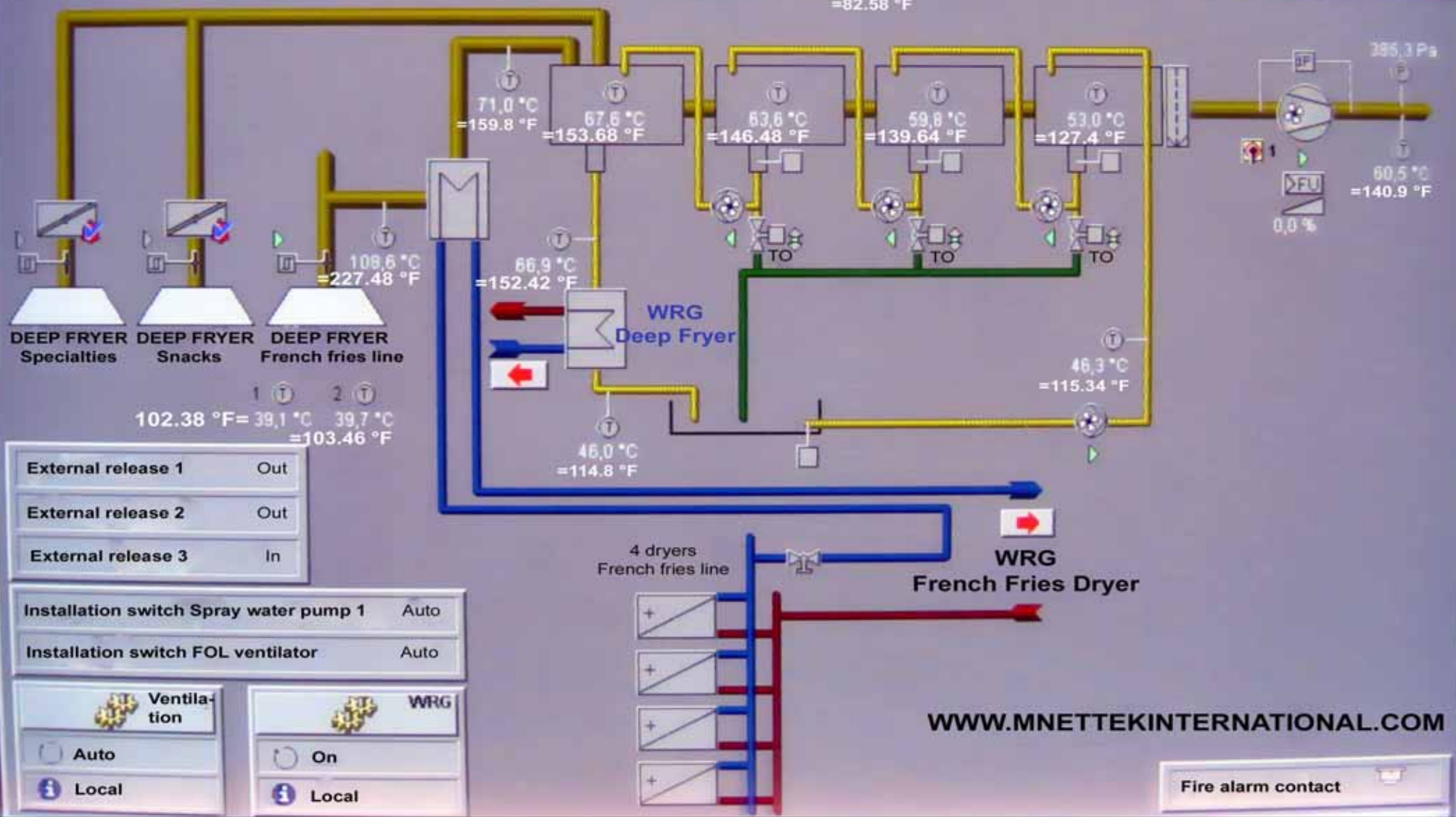

28,1 °C
=82,58 °F

385,3 Pa

71,0 °C
=159,8 °F

67,6 °C
=153,68 °F

63,6 °C
=146,48 °F

59,8 °C
=139,64 °F

53,0 °C
=127,4 °F

60,5 °C
=140,9 °F

108,6 °C
=227,48 °F

66,9 °C
=152,42 °F

46,3 °C
=115,34 °F

46,0 °C
=114,8 °F

102,38 °F = 39,1 °C
39,7 °C = 103,46 °F

External release 1	Out
External release 2	Out
External release 3	In

Installation switch Spray water pump 1	Auto
Installation switch FOL ventilator	Auto

Ventilation	WRG
<input type="radio"/> Auto	<input type="radio"/> On
Local	Local

4 dryers
French fries line

WRG
French Fries Dryer

WWW.MNETTEKINTERNATIONAL.COM

Fire alarm contact

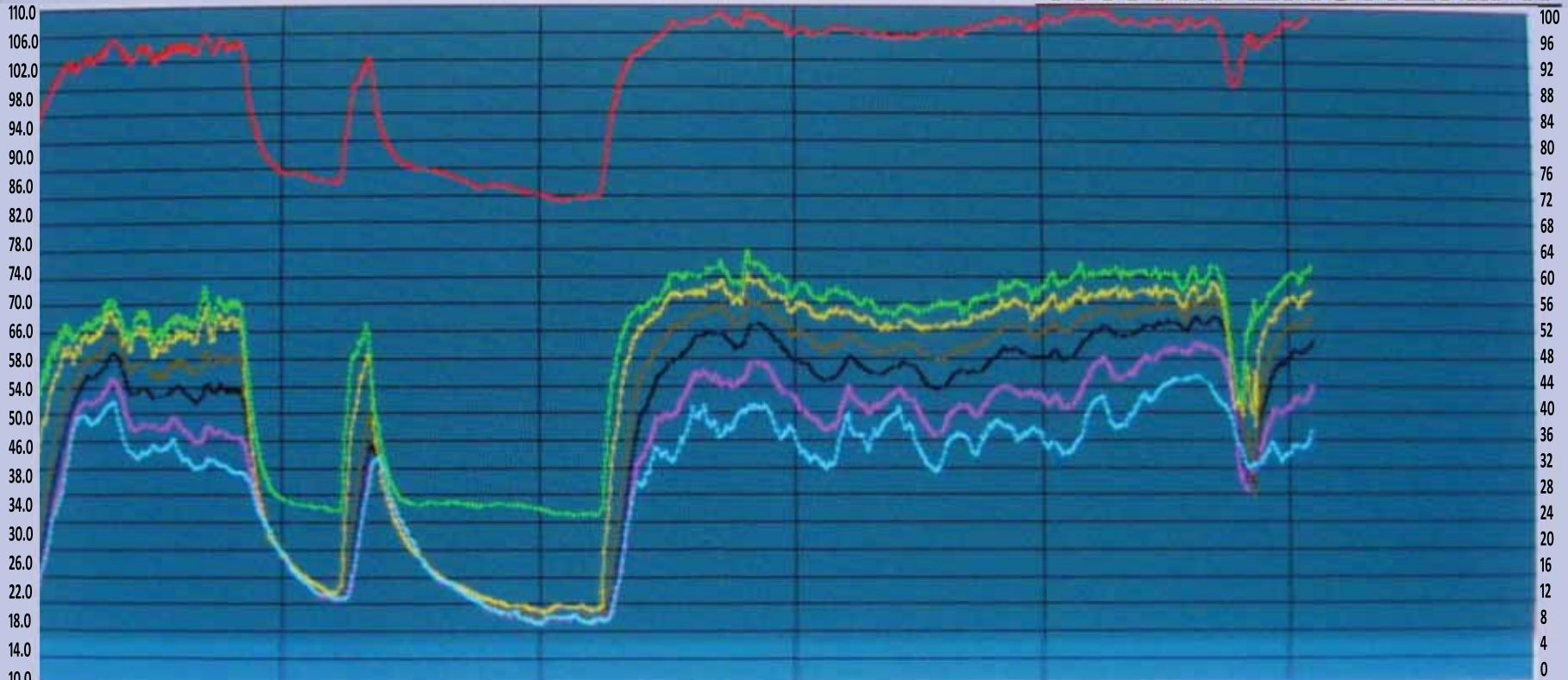

23:30:00 20 Jul 2009 02:00:00 21 Jul 2009 04:30:00 07:01:00 09:30:00 12:01:00

23:30:00 20 Jul 2009 15:00:00 14:30:00 21 Jul 2009

- WG17RE'O'8003 AI [Temp spray water cold] 117.9 °F/ 47.7 °C
- LU17'RE'O'8001 A1 [ABL Temp ABL Deep Fryer] 227.8 °F/ 108.8 °C
- WG17RE'O'8003 AI [Conduit temperature spray water system Sect. 3] 147.2 °F/64 °C
- WG17RE'O'8001 AI [Conduit temperature spray water system Sect. 1] 129 °F/53.9 °C
- WG17RE'O'8005 AI [Conduit temperature spray water inflow WRG] 161 °F/71.7 °C
- WG17RE'O'8005 AI [Conduit temperature spray water Sect. 4] 155.8 °F/67.8 °C
- WG17RE'O'8002 AI [Conduit temperature spray water Sect. 2] 140.9 °F/60.5 °C

* Bernhard Fercher Company is our European Partner Company in Austria.



FERNETT 
Energy Solutions LLC

WWW.MNETTEKINTERNATIONAL.COM

